

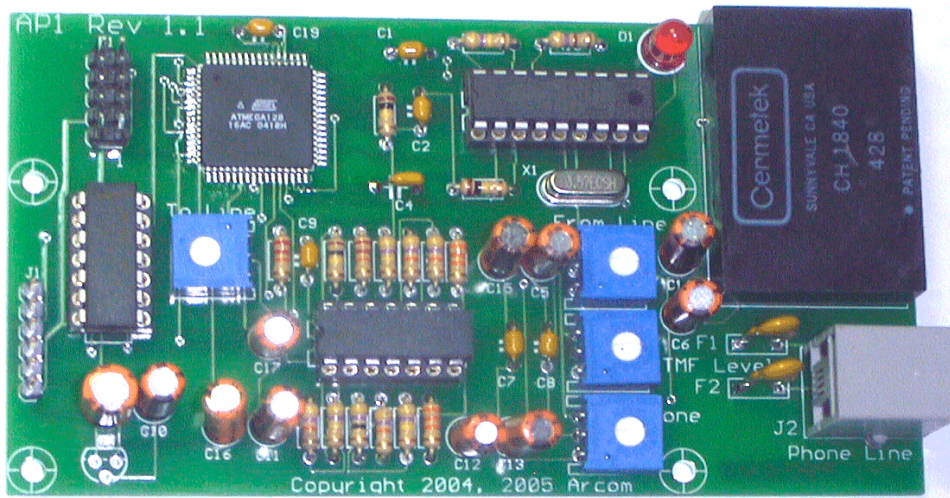

Arcom Communications
24035 NE Butteville Rd
Aurora, Oregon 97002
(503) 678-6182
arcom@arcomcontrollers.com

<http://www.arcomcontrollers.com/>



AP1 Autopatch Manual

Hardware Revision 1.2

January 13, 2004

Reproduction or translation of any part of this manual beyond that permitted by sections 107 or 108 of the 1976 United States Copyright Act (or its legal successor) without the express written permission of Arcom Communications is unlawful as noted below. Requests for permission to copy or for further information should be addressed to Arcom Communications. Except as noted above, permission is hereby granted for any non-profit group or individual to reproduce any portion of this document provided that: the reproduction is not sold for profit; the intent of reproduction is to further disseminate information on the RC210 Repeater Controller kit; the reproduction is not used for advertising or otherwise promoting any specific commercial product other than the RC210; and full credit is given to Arcom Communications as the original source of information.

The information contained in the manual has been carefully checked for accuracy and is believed to be entirely reliable. However, no responsibility is assumed for inaccuracies. Arcom Communications reserves the right to make changes in the RC210 Repeater Controller kit to improve reliability, function or design without obligation to purchasers of

previous equipment. Arcom Communications does not assume any liability arising out of the application or use of any product or circuit described herein; neither does it convey license under its patent rights or the rights of others.

(This page intentionally blank)

INTRODUCTION	5
FEATURES	5
DESCRIPTION OF FEATURES	6
<i>AutoDial Memories</i>	6
<i>Phone Number Blacklist (dialing restrictions)</i>	6
<i>Reverse Patch</i>	6
CASE MODIFICATION.....	7
MOUNTING THE AP1 IN THE RC210R RACK MOUNT	7
CONNECTING THE AP1 TO THE RC210	8
FIRST TIME PROGRAMMING.....	9
ADJUSTMENTS	9
<i>Phone Line To Radio Level</i>	9
<i>Dialing DTMF To Phone Line Level</i>	9
<i>Radio To Phone Line Level</i>	9
<i>DTMF Decoder Level</i>	9
OPERATION	10
DIALING A NUMBER.....	10
<i>Manual Dialing</i>	10
<i>AutoDial</i>	10
<i>Ending The Call</i>	10
<i>Extending the Time Out Timer</i>	10
<i>Inserting A Pause</i>	10
REVERSE PATCH	12
PROGRAMMING THE AP1	13
<i>Enabling/Disabling the Autopatch</i>	13
<i>Allowing Direct Dialing</i>	13
<i>Programming the Autopatch Command Prefix Code</i>	13
<i>Programming the Security Code</i>	13
<i>Autopatch Time Out</i>	14
<i>Number of Rings To Answer</i>	14
AUTODIALER.....	14
DIALING RESTRICTIONS.....	15
FCC REGISTRATION INFORMATION.....	16
PC BOARD LAYOUT	17

Introduction

Congratulations on your purchase of the AP1 Autopatch Board. The AP1 is designed for use with our RC-210 Deluxe Repeater Controller (pc board versions 2.8 & 3.0) and is an intelligent design with its own on-board microprocessor. This allows for a very powerful autopatch board while requiring very little support from the host RC210. Connection of the AP1 is very straightforward and doesn't "use up" a radio port on the controller. Two connections (plus your phone line) is all that is required.

The AP1 measures 4.25" x 2.5" and mounts in our RC210R Rack Mount Enclosure (or may be mounted externally)

Features

- 200 number auto dial memories
- Selectable toll restrictions by area code
- Selectable long distance restriction
- Black list of phone numbers, using specific phone numbers or wildcards
- FCC registered under Part 68
- Reverse Patch
- Programmable Time Out Timer
- Programmable number of rings to answer or disable Answer
- Programmable Answer Security Code
- Resettable Command Timer that automatically hangs up after 2 minutes of non-activity from phone line
- On-board, dedicated DTMF decoder
- Regenerated DTMF used to dial phone number
- On-board microprocessor
- Works with Version 4.30 and higher of RC210 firmware
- No external power needed. The AP1 draws its operating power from the RC210

Description Of Features

AutoDial Memories

The 200 Autodial memories are stored in the AP1's non-volatile memory and may consist of up to 10 digits, representing area code and number to be dialed. These are designed to be stored by the system operator and not by the general usership.

Phone Number Blacklist (dialing restrictions)

The AP1 incorporates a very flexible Blacklist. This Blacklist allows you to allow or disallow long distance calls, area codes and specific numbers. Just about any combination is accommodated.

Reverse Patch

The AP1 provides for reverse patch operation by answering the phone after a programmed number of rings. Once the AP1 "answers" the ringing phone, the caller has 20 seconds to enter the Security Code (the Security Code is programmable and may be up to 15 digits long). If the proper code is not entered within this period of time, the AP1 will automatically hang up.

Once the proper Security Code is entered, as long as the caller enters any DTMF digit and the Command Evaluation Digit (also programmable) every 2 minutes, the connection will remain active. If no Command Evaluation Digit is received by the AP1 within this time period, the AP1 will also automatically hang up. This protects against a disconnected phone call.

While connected, the caller has complete access to all functions within the RC210 including linking, programming commands and "Control Receiver" operation (see the RC210 Operations and Programming Manual for a full description of Control Receiver operation).

Please note that you must have firmware version 4.30 or later installed in the RC210 in order to use the AP1. If necessary, refer to the RC210 Operations and Programming Manual for directions on how to upgrade the firmware.

Case Modification

If you previously purchased our RC210R Rack Mount, you will need to cut out an opening in the back panel of the RC210R to allow the RJ11 from your phone line to be plugged into the connector on the AP1.

Follow the diagram below for locating the proper position for the cutout.

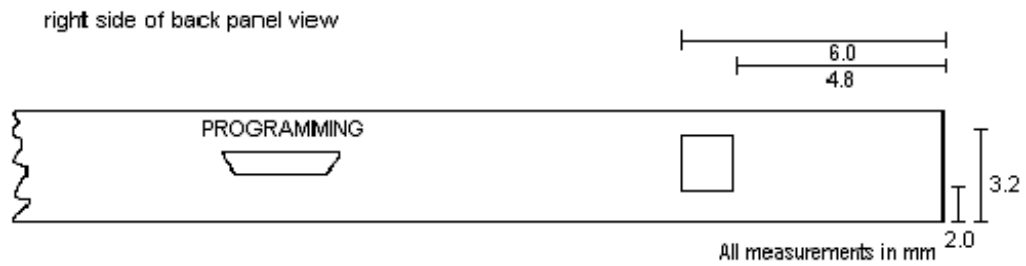

Mounting the AP1 in the RC210R Rack Mount

The AP1 is designed to be mounted on the set of standoffs farthest from the RC210 board. Use 4 ea. 4-40 screws to mount the AP1

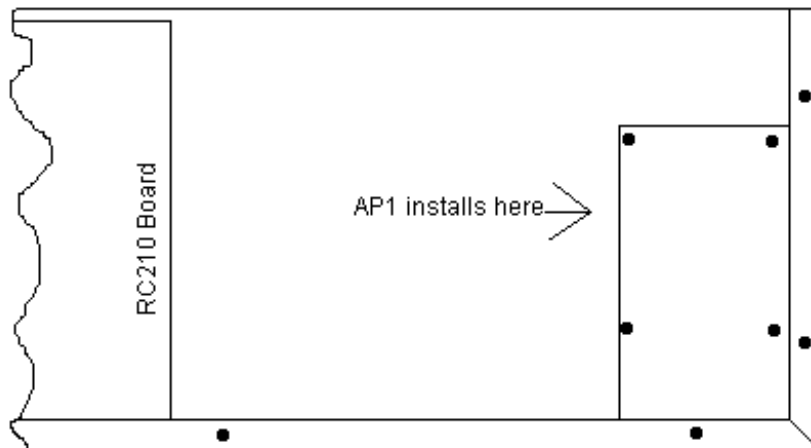

Connecting The AP1 To The RC210

There are two cables connected to the AP1's J1 position on the board. One cable has a 6 pin header connector (P1) on one end. The other cable has either an 8 pin header connector (P2) or a 6 pin header connector (P2). First, make sure power is removed from the RC210.

Refer to the following for making these connections:

P1 is connected to J9, labeled "Audio Expand" on the RC210. Be sure to line up the red mark on P1 with the "1" on the PC board.

RC210 Version 2.8 PC Board

P2 (8 pin) is connected to J7, labeled "I/O Expand" on the RC210. Be sure to line up the red mark on P2 with the "1" on the PC board.

RC210 Version 3.0 PC Board

P2 (8 pin) is connected to J5, labeled "Audio Expand" on the RC210. Be sure to line up the red mark on P2 with the "1" on the PC board.

J2 on the AP1 board (the RJ11 jack) connects to your phone line.

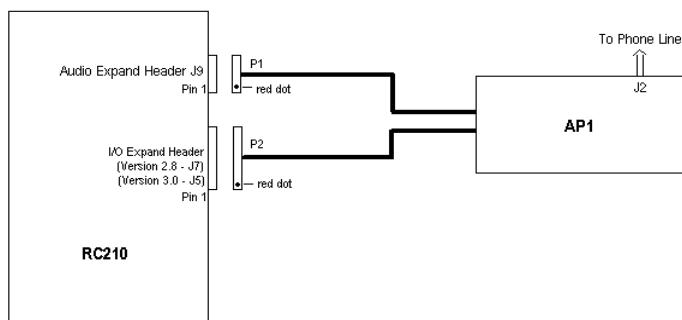

Note: The 10 pin header P1 is used for factory programming and is not used in normal operation

Power up the RC210 and you are now ready to proceed to Adjustments.

First Time Programming

If you are adding your AP1 to an existing RC210 installation, you'll need to program a few things before you can proceed to adjust and use your AP1. Additionally, if you have a firmware version earlier than 4.30, you must load in the latest update (> Version 4.30) before you will be able to use the AP1.

If you purchased your AP1 at the same time you purchased your RC210, you may skip over this section and go immediately to Adjustments.

In order to enable Autopatch operations for the first time, unlock the RC210 and enter each of the following commands (you can always modify these later as explained in the Programming section of this manual).

***2061 C 1**

***2063 1 2 3 4**

2701

Lock the controller and you are now ready to move to Adjustments below.

Adjustments

There are four adjustments that are needed before your AP1 can be placed into operation. Refer to the PC board layout at the end of this manual to help locate the trimpots you will adjust.

Phone Line To Radio Level

Using a DTMF equipped radio, enter **C11**. The controller will respond with "Auto Patch Ready" and you should then hear dial tone. Adjust R7, marked "From Line" for the proper level from your transmitter. Enter **C10** to hang up.

Dialing DTMF To Phone Line Level

Turn R18, marked "Tone", full counterclockwise. Using the radio, enter **C 1 1 <any 10 digits you want>**. Be ready to adjust R18 quickly, once the RC210 says "Auto Patch Ready". 2 seconds after you first hear dial tone, the AP1 will send DTMF to the phone line. Adjust R18 until the sent DTMF "breaks" dial tone. If necessary, hang up using **C 1 0** and repeat. The goal here is to use the minimum level for reliable dialing.

Radio To Phone Line Level

At this point, you should be able to manually dial a phone number, using the radio, **C 1 1 <number>**. The RC210 will respond with "Auto Patch Ready" then you'll hear dial tone. There will be a 2 second delay and your number will be dialed.

You should call someone you have made arrangements with and adjust R8, marked "To Line" for a reasonable level. While you want to take care not to overdrive the phone line, the AP1 has an internal limiter that will prevent too much level being delivered to the phone line. However, it is possible for the audio to become distorted if set too high. You should adjust R8 for distortion free, clear audio into the phone line. When you are done, use the radio and enter **C 1 0** to hang up.

DTMF Decoder Level

Turn R14, marked "DTMF" fully counterclockwise. For this next adjustment, it is necessary to call the phone line to which the AP1 is connected. The AP1 should answer on the 2nd ring.

After it answers, you only have 20 seconds to make this adjustment. Push and hold any DTMF digit on the calling phone and quickly turn R14 clockwise until the red LED (D1) lights. Let the AP1 "hang up" on you and then call it back. From the phone, enter **1 2 3 4 #**. You should see the LED light for every digit. If successful, the AP1 will respond by sending a CW " R ". Enter ****** #** from the phone and the AP1 will hang up.

Operation

All non-programming commands for the AP1 (dialing, recalling autodial number, hangup), are placed together in one grouping of commands, all prefaced by a command prefix. By default, this prefix is "C1" (however you can change this to be anything you like, up to 4 digits).

After a user dials a number (or uses the autodialer) and unkeys, the controller will announce that autopatch function and will then take the phone off hook. The user will hear dialtone for 2 seconds before the phone number is actually dialed. This delay is due to FCC regulations that require a 2 second "billing delay" period before actually dialing the number. After the number is dialed, the Call Timeout Timer is started that will limit the length of that call. This timer is programmable (see the Programming section of this manual). If it times out, the hangup message will be played and the phone placed on hook.

Dialing A Number

The AP1 provides for manual dialing of a phone number and recalling one of 200 previously stored autodial numbers.

Manual Dialing

<Autopatch Prefix> 1 <phone number> Take offhook and manually dial a phone number. The AP1 will accept both 7 and 10 digit formats.

AutoDial

<Autopatch Prefix> 2 <Autodial memory 1 - 200> Take offhook and dial memory 1 - 200

Ending The Call

When the user is finished with their phone call, they may hang up the phone using the following command:

<Autopatch Prefix> 0 Hang up

Otherwise, the call will be ended when the Call Timeout Timer expires.

Extending the Time Out Timer

There may be times where a phone call may need to be unusually long, such as during an emergency. This command may be used to extend the time out period. For example, if the timer is programmed to end the call in 5 minutes, this command will allow that time to be extended an additional 5 minutes. This command may be used as often as needed.

<Autopatch Prefix> 3 Extend call for another time out period

Inserting A Pause

Sometimes it may be necessary to insert a pause in the dialing sequence, such as when accessing an outside line on a PBX style system. By inserting an A in the dialing sequence, a 2 second pause will be introduced. This may be used for either manual dialing or stored in an Autodial slot

Example : <Autopatch Prefix> 1 9 A 5 5 5 1 2 1 2 ←-This will insert a 2 second pause between the 9 and first 5

Reverse Patch

The AP1 allows you to "call in" and gain access to all RC210 commands. This is very useful for positive control operator use.

When you call the AP1, it will answer after the amount of rings are received that you have programmed as the Number Of Rings To Answer (see page 12). Once the AP1 answers, you have 20 seconds to enter your Security Code (see page 12). If not received within this 20 second window, the AP1 will automatically hang up.

Once the Security is successfully entered, the connection will be maintained as long as the *Phone Terminator Digit* is entered at least once every 2 minutes (the *Phone Terminator Digit* is a " # " and cannot be changed). Also, the AP1 will send a Morse Code "R" to the phone line upon successful connection in this manner.

Since there is no COS signal from a phone line, all commands entered via the phone line must have the phone terminator digit appended to the end of entered commands, in order to let the AP1 know it should evaluate the digits entered. For example, if your Security Code is set to "1 2 3 4", you would enter " 1 2 3 4 # " from the phone line. The same holds true for commands you want to enter for the RC210. For example, if Port 1's unlock code is " 1 5 2 8 1 ", you would enter " 1 5 2 8 1 # ".

The AP1 will automatically translate the # into the correct Terminator Digit you use in the RC210. In other words, if you redefined the Terminator Digit in the RC210 to be " A ", the AP1 will take care of changing the " # " you enter from the phone line into " A " when it sends the command to the RC210.

While connected to the AP1 from the phone line, the caller will have full access to all RC210 command codes. However, if the Security Code is never entered from the phone line, the party on the phone will not have access, even if the autopatch call was placed by an on-the-air user.

When commands are entered from the phone line, the RC210 will send its speech back to the phone line.

Lastly, when a Reverse Patch is in progress, the normal Time Out period does not apply. This means that once a Reverse Patch is started (the Security Code was successfully entered) the session will last forever, as long as the Phone Terminator Digit is sent at least once every 2 minutes.

To end the connection when you're finished, you can either enter " * * * * # " or simply hang up and let the AP1 time out. In this last case, the AP1 will hang up within 2 minutes.

Connecting to a Port

There may be times you want to connect to a Port on the RC210 so you can communicate with users on the air. You may do this by using the following code

789 x where x is the Port you wish to connect to

Programming The AP1

Several aspects of the operation of the AP1 may be custom programmed. As these commands require unlocking of the RC210, these commands are generally reserved for the owner.

Enabling/Disabling the Autopatch

The Autopatch may be programmed to allow access only from certain RC210 Ports.

***2116x** where x is the port(s) to allow:

- 0 = Disable Autopatch on all ports
- 1 = Port 1
- 2 = Port 2
- 3 = Port 3
- 12 = Ports 1 & 2
- 13 = Ports 1 & 3
- 23 = Ports 2 & 3
- 123 = All Ports

Also, Disabling the Autopatch does not disable the ability to use the Reverse Patch to access the controller.

Allowing Direct Dialing

Under normal circumstances, the AP1 regenerates DTMF sent to the phone line for dialing. In other words, DTMF from user is not allowed to be passed to the phone line. This is done to prevent the user from circumventing any dialing restrictions you may have programmed.

However, there may be times where you want to be able to pass DTMF to the phone line. This command will allow you to select that:

- 2701** Don't allow DTMF to be passed to phone line
- 2700** Allow DTMF to be passed to phone line.

Programming the Autopatch Command Prefix Code

When programming the following two codes, bear in mind that * and # are reserved digits and may not be used in these codes. As shipped from the factory, the default Autopatch Command Prefix is C1. You may change that using this command:

***2061 xxxx** where xxxx is up to a maximum of 4 digits

Programming the Security Code

The Security Code is used to prevent unauthorized access from the phone line. When the AP1 answers an incoming call, the caller has 20 seconds in which to enter the correct code. If it is not entered within this time, the AP1 will hang up. You may program that code with this command. Remember that most telephones do not have a 4th column, so you should restrict the digits used to 0 -9.

***2063 x** where x is your code, up to a maximum of 15 digits

Autopatch Time Out

The maximum duration of a phone call may be limited using this command:

***1024 x** where x = 30 to 32767 in seconds. Programming a value less than 30 will actually program a value of 30.

Number of Rings To Answer

You may program the number of rings required for the AP1 to "pick up" the phone line:

***1025 x** where x = 1 to 255. **Programming a 0 will disable answering.**

AutoDialer

By storing autodial memories for your users, containing frequently called numbers, you can make operation of the AP1 that much easier. When storing autodial memories, it is important to note that you must use 3 digits when designating the autodial memory number:

***2115 xxx yyy-yyy-yyyy** where xxx is the 3 digit autodial number 001 - 200. yyy-yyy-yyyy is the phone number to be stored.

NOTE: If your local telephone company does not require the use of area codes when dialing, you may use only 7 digits. However, the AP1 will accommodate up to 10 digits in each autodial memory.

Dialing Restrictions

The AP1 provides a very versatile method of implementing dialing restrictions by the means of a *Blacklist*. This Blacklist allows you great flexibility in how you want to prevent phone numbers from being called.

There may be certain phone numbers you never want allowed dialed. There may be blocks of phone numbers you want to disallow. For example, you may not want users to be able to dial any 900 number. Or maybe you want to disallow the calling of area codes other than your local one. Or further still, you may want to prevent specific phone number from being dialed. The Blacklist allows you to do all this with ease.

The Blacklist will hold up to 100 different number combinations. The format of the command is:

***2062 xxx <parameter>** where xxx is the 3 digit Blacklist slot 001 - 100 and <parameter> is the number (or otherwise) you want to store in that slot.

When programming specific numbers, the Blacklist accepts either 7 or 10 digit format phone numbers.

Note: You may erase any Blacklist slot by entering just a 0. For example: *2064 001 0 will erase slot #1

Examples:

***2062 001 555 1212** Don't allow 555-1212 to be dialed and store in Slot 1
***2062 022 503 555 1212** Don't allow 503-555-1212 to be dialed and store in Slot 22

By using the wildcard character - an asterisk (*) - you tell the AP1 to consider any digit appearing after it as a match. For example, don't allow any phone number in the 900 area code to be dialed:

***2062 005 900 *** Store in Slot 5

Or maybe you want to disallow the phone company's repair number to be dialed:

***2062 010 611** Store in Slot 10

Notice in this last example, no wildcard is needed, as "611" is the complete number you'd dial to call repair.

And finally, if you want to disallow dialing of any long distance phone number (those starting with a 1):

***2062 006 1 *** Store in Slot 6

FCC Registration Information

1) UPON REQUEST ONLY, you must provide the following data to your telephone utility company (telco):

- a) Notice of intention to install or permanently remove an FCC Part 68 registered device or system, and the FCC Registration Number.
- b) The Ringer Equivalence Number (REN) (see device label). Note that if several devices are connected to the same line, the RENs must not add up to more than 5.0 (A or B). This REN figure is important to your telco.
- c) The (USOC) jack type to be provided by telco. typically this will be RJ-11C/W for single lines.

2) This device may not be used on telco-operated coin phone lines. Party lines and privately owned coin-phones are subject to local State regulatory policies, and possible additional State special requirements.

3) The telco has the right to make changes to their network, which may affect the operation of your equipment, provided you are given adequate advance written notice to permit correct operation.

4) In cases of operational problems, disconnect your unit by removing the modular plug from the telco jack. If your regular phone (or other device or system) still works properly, your AP1 has a problem and must remain disconnected and (officially) serviced or returned for repairs. If upon the above disconnection your regular service still has problems, notify your telco that they may have a problem. Request prompt service at no cost to you the user. If a problem is found in premises wiring not telco installed, you are subject to a service charge. If a fault is in telco installed wiring, you may be subject to a service call charge.

5) Unless otherwise noted in the User's Manual (eg: fuses, etc.), user may not under any circumstances (in or out of warranty) attempt any service, adjustments or repairs on this unit. It must be returned to the factory or authorized U.S. service agency for all such work. Locations (or phone numbers) of factory or authorized U.S. service points are listed in this user's manual.

6) Special FCC rules apply to equipment connected behind PBX or KTS.

7) Procedure for Plugs and Jacks; Arcom Communications attests that the network interface plugs or jacks used on this equipment comply with and will continue to comply with the mechanical requirements specified in Part 68. Subpart F. Specifically the dimensions, tolerances and metallic plating requirements. The compliance of these connectors will be assured by purchase specifications and incoming inspections.

PC Board Layout

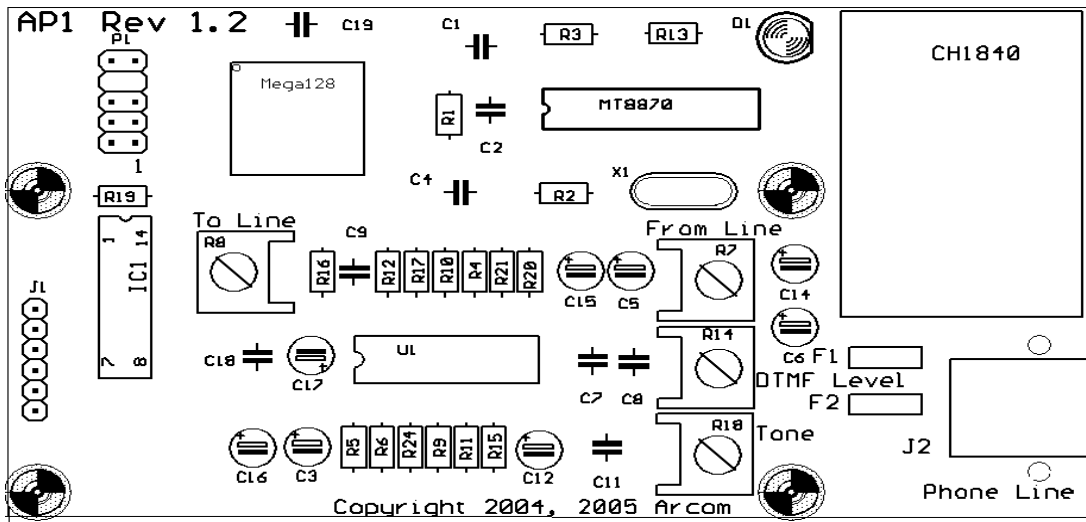

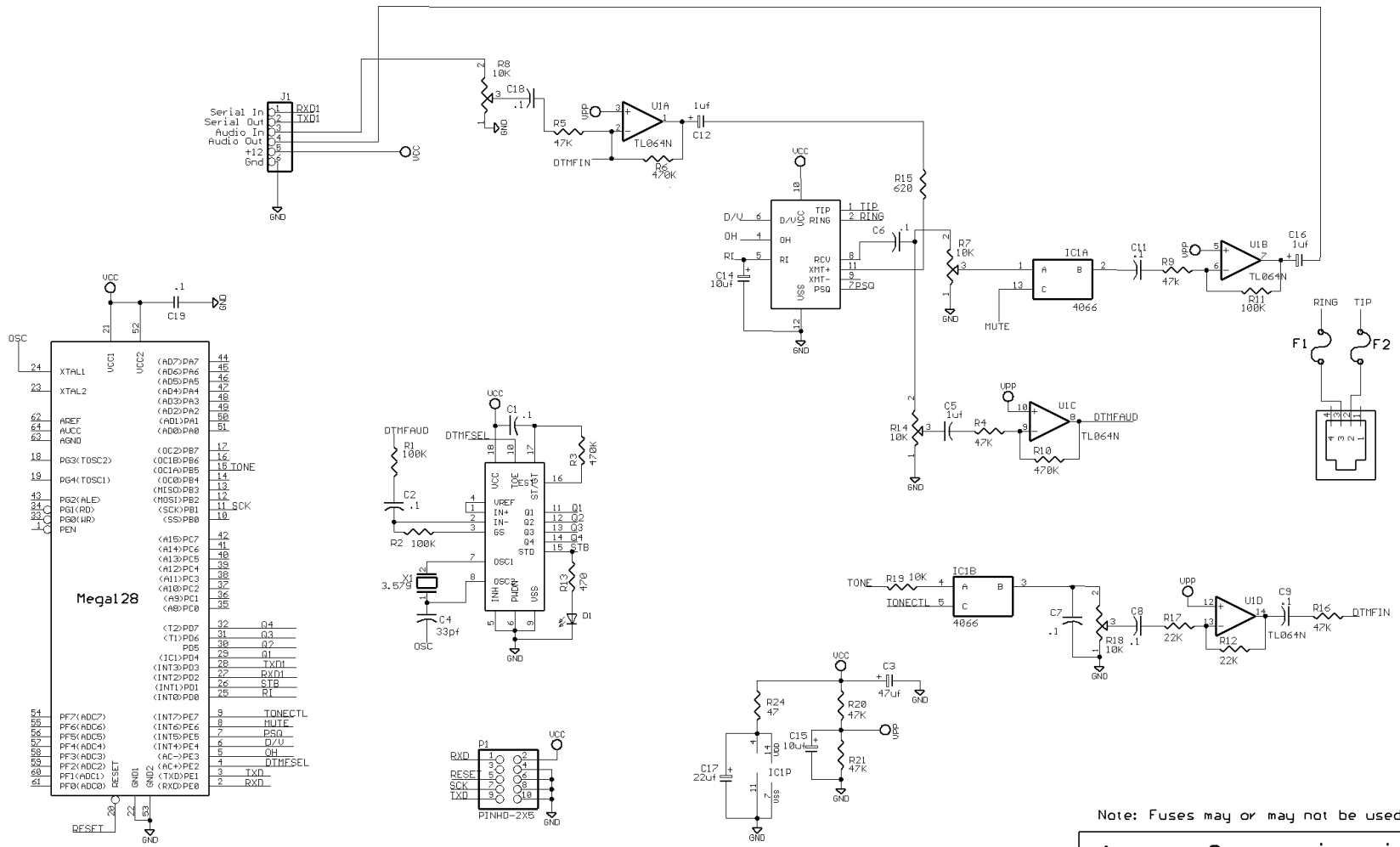

Note: Fuses may or may not be used

Arcom Communications

TITLE: API

Document Number: REV: 1.2

Date: 1/06/2005 08:16:21a Sheet: 1/1